



- Disassembly
- Accessory Installation
- Function Check
- Reassembly
- Visual Check
- Trouble Shooting

KMA Genuine Approved Accessories

Vehicle Model	Forte Sedan & Koup	Accessory	EC Mirror w/ Compass
Model Year	2010	Difficulty	(A) - (B)
KMA Part No.	U8620 1M000	Pamphlet No.	550-0516
Vendor Part No.	905-2374-002KTD	Revision No.	0000001

Note: Difficulty stated above reflects the minimum level of expertise required to install the accessory
 (A) Customer (B) Dealer Technician (C) Master Technician

Instructional Symbols / Definitions

 Denotes warnings that may lead to serious physical injury or vehicle damage.	 Denotes quality processes to be checked prior to moving to the next step.	Denotes safety equipment required to be used such as a mask, goggles, rubber gloves, and hearing protection.	
 Denotes cautions to be taken to avoid physical injury or electronic component damage.	 Denotes specific tools that are necessary to complete the step.	 Mask	 Goggles
 Denotes cautions to be taken to avoid vehicle and component damage.	 Denotes instructional steps necessary to complete this process.	 Rubber Gloves	 Hearing Protection

Basic Required Hand Tools

 Panel Removal Tool	 Needle-nose Pliers	 T20 Torx Driver	 Ratchet
 10mm Socket	 6" Socket Extension	 #2 Phillips Screwdriver	 Side Cutters
 4mm Screwdriver	 Torque Wrench		

Specialty Required Tools

Note to the Installer

- Read the entire installation pamphlet prior to beginning the installation of the accessory.
- Ensure that the vehicle is properly protected in the area that the accessory is to be installed.
- To prevent vehicle damage, never place tools on top of painted surfaces, seats, dash pad, console or floor carpet / mat.
- Always wear appropriate safety gear to include gloves and eye protection when required.

KMA Genuine Approved Accessories

Kit Overview

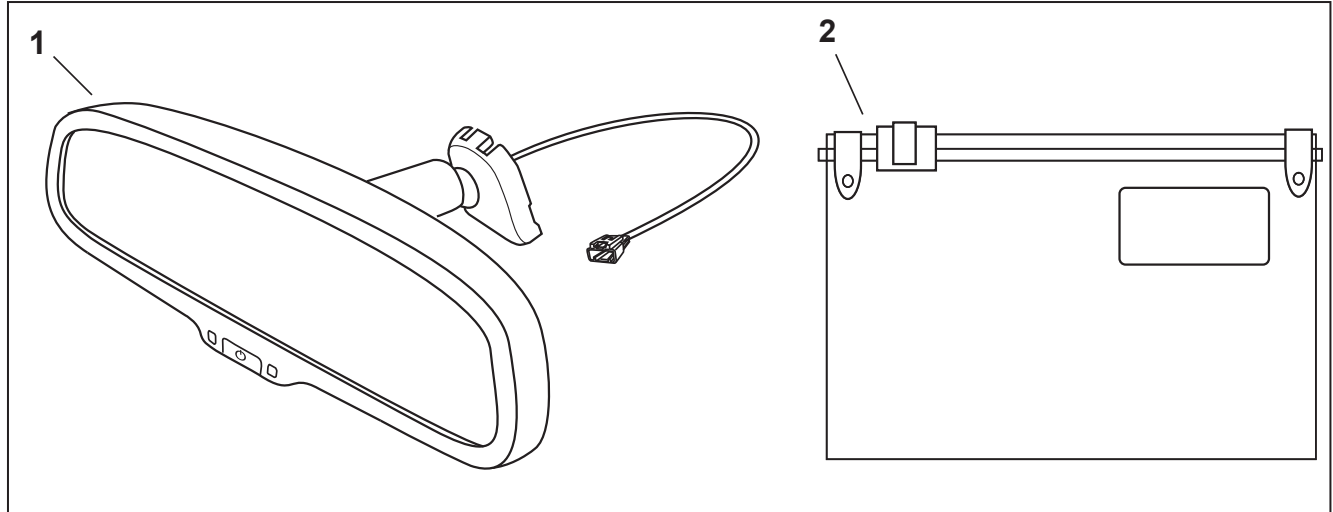

No.	Qty.	Description	No.	Qty.	Description	No.	Qty.	Description
1	1	EC Mirror w/ Compass						
2	1	Hardware Kit						

Hardware Kit Review

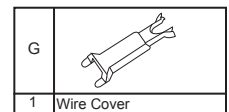
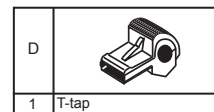
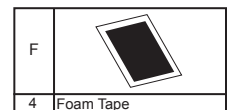
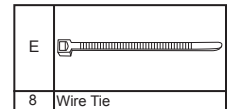
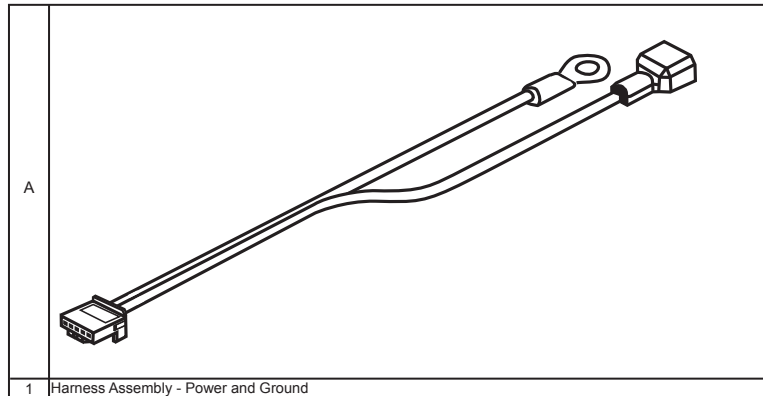

Hardware Kit Total
17

KMA Genuine Approved Accessories (Disassembly)

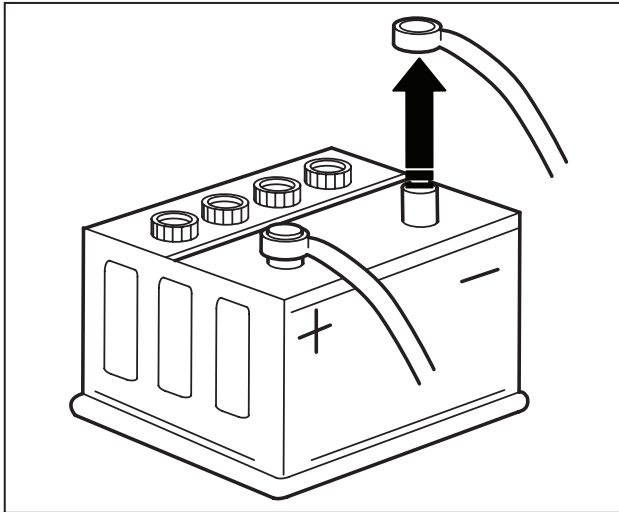

	Ratchet & 10mm Socket	1
NOTE	Record all pre-set radio stations. Disconnect and isolate vehicle's negative battery terminal.	
	CAUTION: DO NOT touch vehicle's negative battery terminal to vehicle's positive battery terminal.	

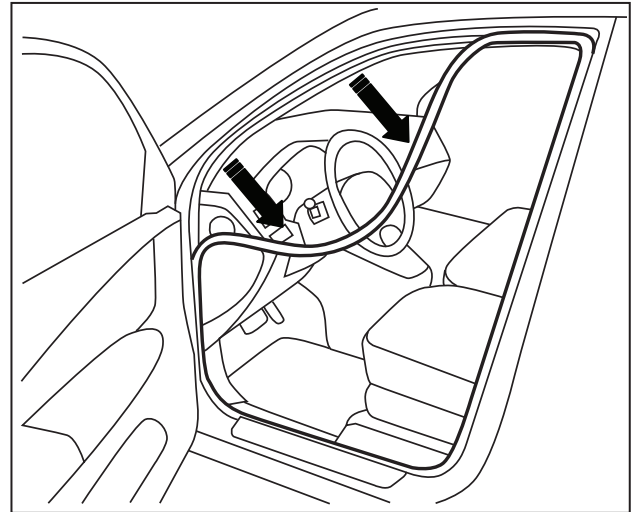

		2
NOTE	Pull front of driver-side door seal back to allow removal of A-pillar trim and side dash trim panel. On KOUP MODEL, only remove lower section of door seal next to side dash trim panel.	
	Note: On KOUP MODEL, do NOT completely remove lower section of door seal. Do NOT remove upper section of door seal.	

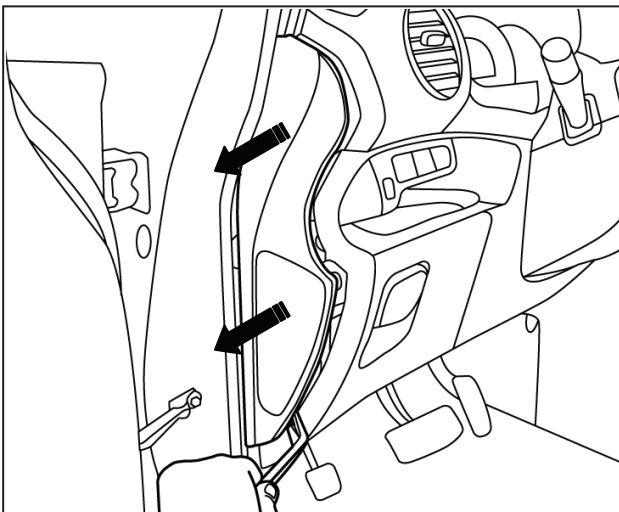

	Panel removal tool	3
NOTE	Remove side dash trim panel.	
	CAUTION: Do not scratch side dash panel.	

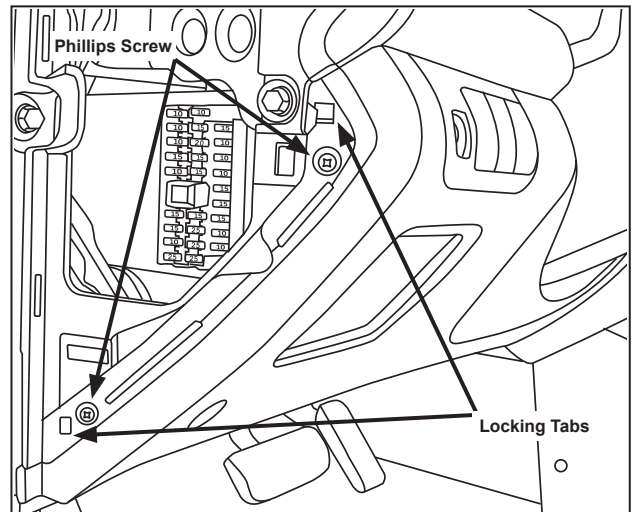

	#2 Phillips screwdriver	4
NOTE	Remove (2) Phillips screws from outside edge of lower dash trim panel.	
	CAUTION: Do not scratch lower dash panel.	

KMA Genuine Approved Accessories (Disassembly)

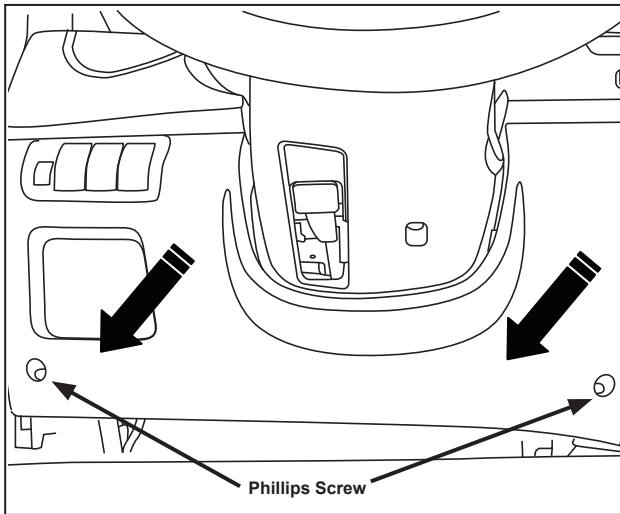

	#2 Phillips screwdriver & Panel removal tool	5
NOTE	Remove (2) Phillips screws from right and left side of lower dash trim panel. Using panel removal tool, release each locking tab, next to the screw locations on side of trim panel. Remove panel until wires and connectors in dash piece are exposed. Unplug all connectors, including the OBD II connector, before completely removing dash trim panel.	
	CAUTION: Do not scratch lower dash trim panel. Do not damage wires or connectors in trim panel.	

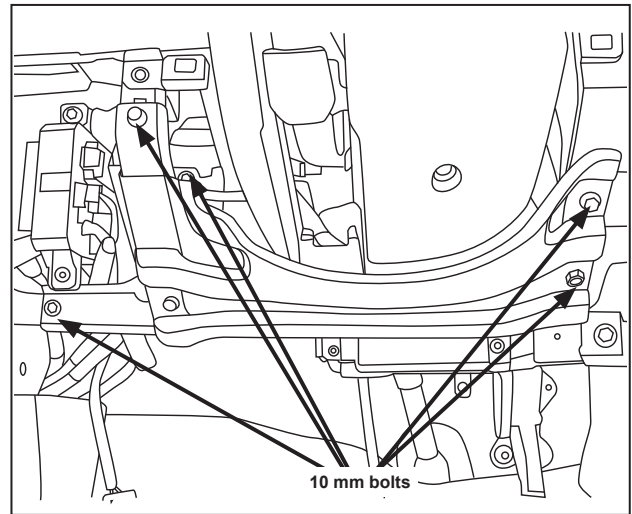

	Ratchet, 6" Socket Extension, & 10mm Socket	6
NOTE	Remove the steel knee bolster plate by removing (5) bolts with 10mm socket.	
	CAUTION: Edges of steel knee bolster and brackets are sharp.	

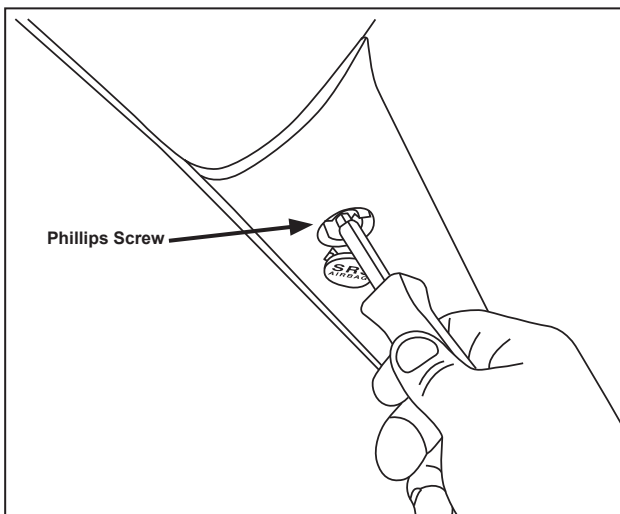

	4mm screwdriver & #2 Phillips screwdriver	7
NOTE	Insert 4mm screwdriver under screw cover in order to remove. Once cover is removed, remove (1) Phillips screw from A-pillar trim.	
	CAUTION: Do not damage A-pillar trim.	

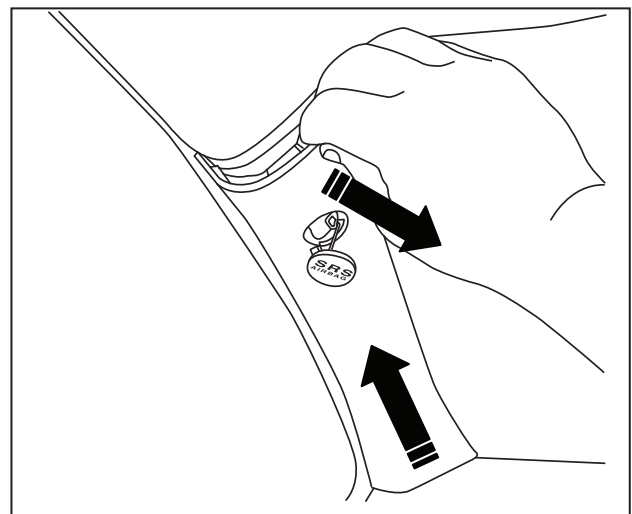

	Panel removal tool	8
NOTE	Remove A-pillar trim by pulling top out towards passenger-side of vehicle and then pulling base upwards toward roof of vehicle.	
	CAUTION: Ensure care is taken to prevent damage to A-pillar and airbag unit.	

KMA Genuine Approved Accessories (Disassembly)

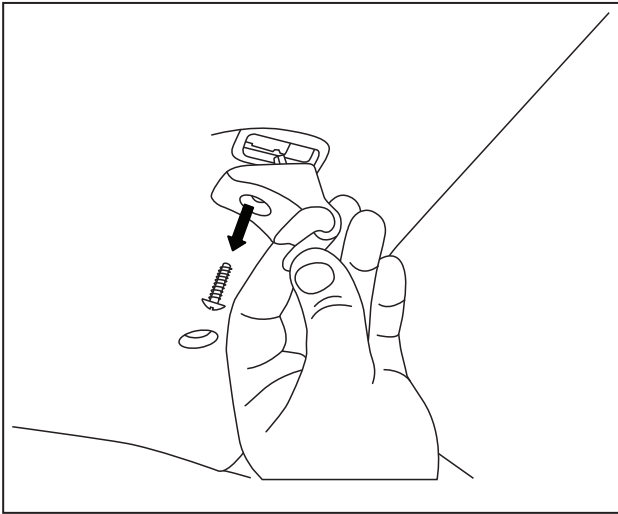

	#2 Phillips screwdriver	9
NOTE	Partially remove driver-side sun visor hook by removing (1) Phillips screw and let hook hang on retaining cup.	
	CAUTION: Do not damage sun visor or headliner.	

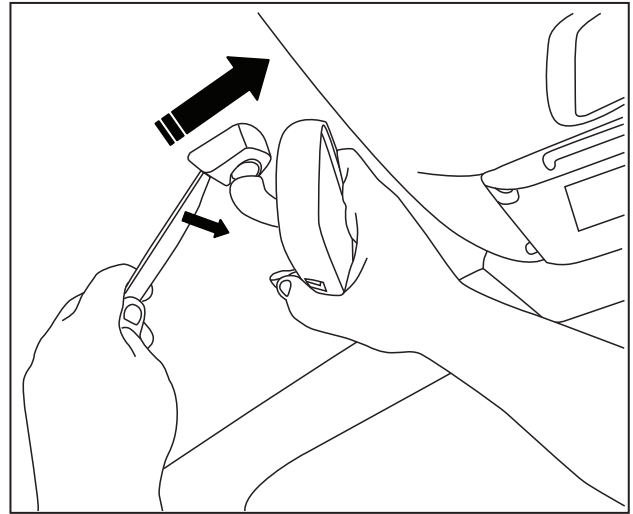

	Panel removal tool	10
NOTE	Using panel removal tool, pull clip on bottom of mount towards the rear of vehicle. With clip still held, tap or pull mirror upwards in a parallel direction to the windshield. DO NOT pull away from windshield.	
	CAUTION: Ensure care is taken to prevent damage to mirror mount, windshield, and headliner.	

KMA Genuine Approved Accessories (Accessory Installation)

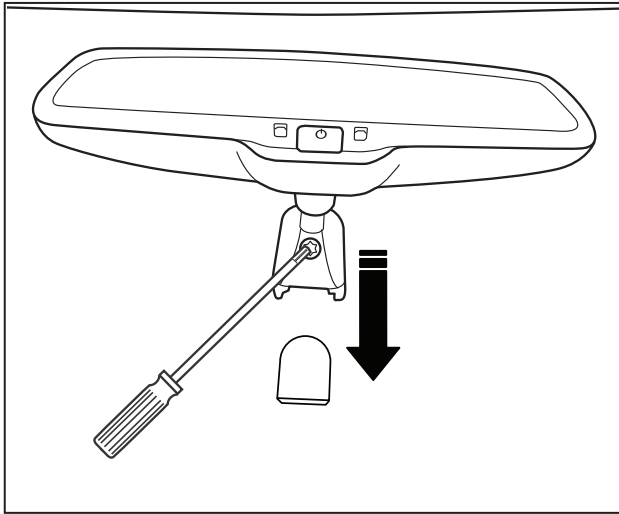

	T20 Torx Driver	1
NOTE	Slide EC mirror onto windshield button.	
	CAUTION: Tighten the mirror mounting bracket screw to 15.6 lbs-in (17.9 kg-cm).	

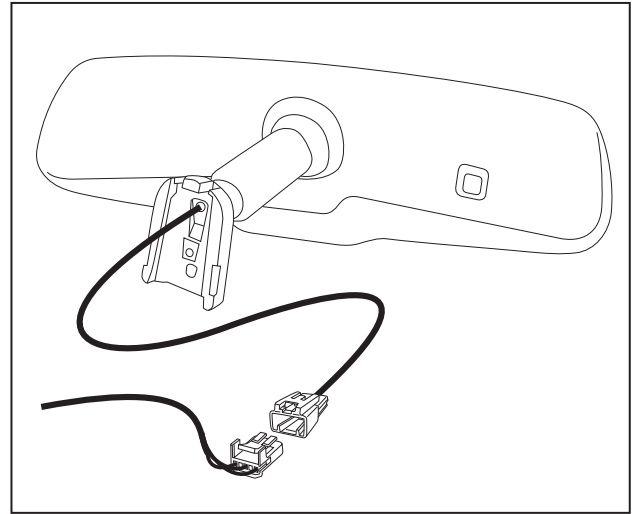

		2
NOTE	Plug 5-pin connector from EC power harness into mirror harness.	
	CAUTION: Ensure 5-pin connector is securely installed.	

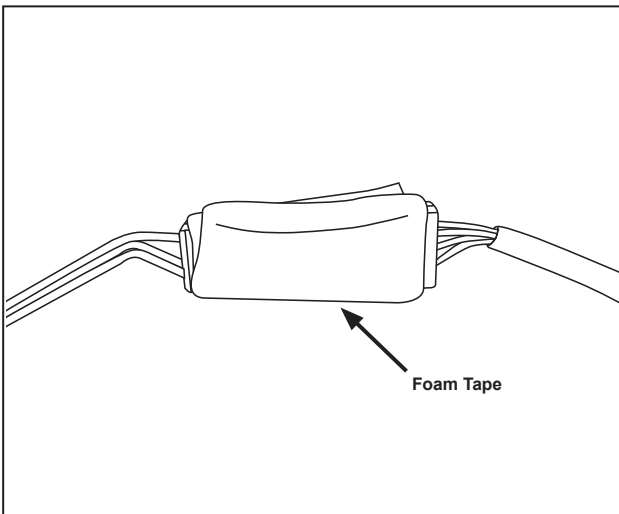

		3
NOTE	Wrap (1) piece of foam tape around EC mirror harness connector.	

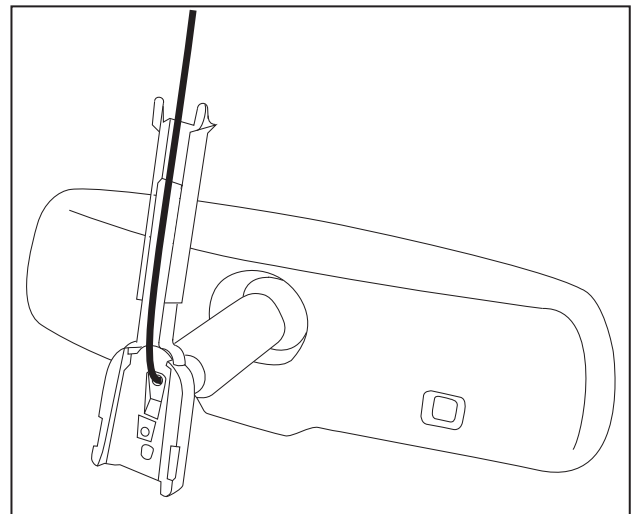

		4
NOTE	Route EC mirror harness into groove of wire cover and attach to the mirror mount. Extend the top of wire cover fully into headliner.	
	CAUTION: Ensure forks are properly seated into mirror and headliner.	

KMA Genuine Approved Accessories (Accessory Installation)

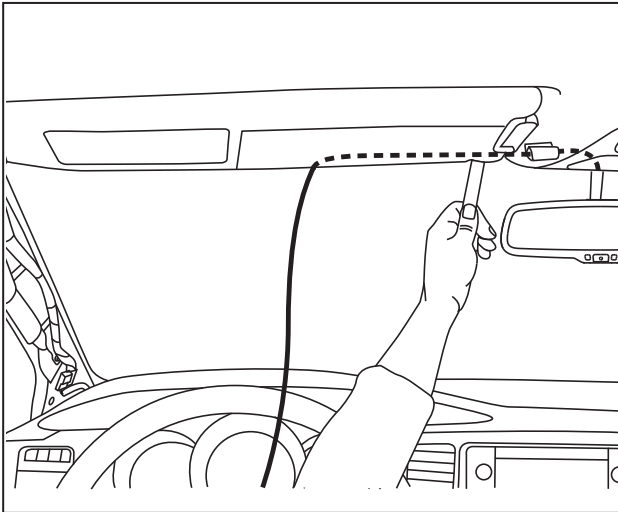

	Panel removal tool	5
NOTE	Tuck the EC mirror harness between the headliner and the roof. Stop just past the visor clip location.	
	CAUTION: Use caution when working with headliner to prevent creases or damage.	

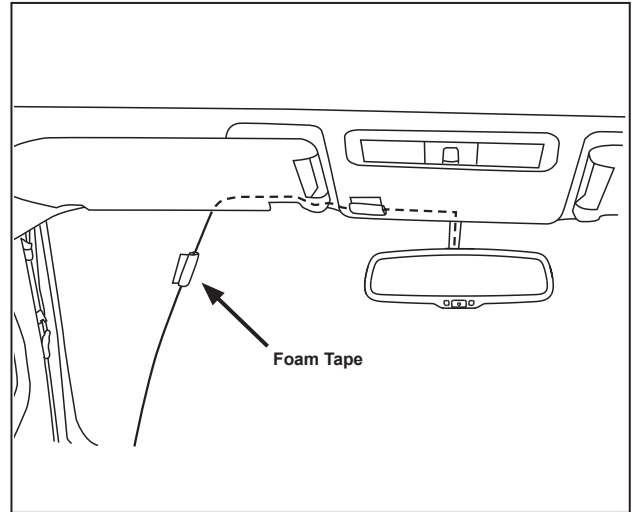

		6
NOTE	Wrap (1) piece of foam tape around EC mirror harness approximately centered above visor.	
	CAUTION: Use caution when working with headliner to prevent creases or damage.	

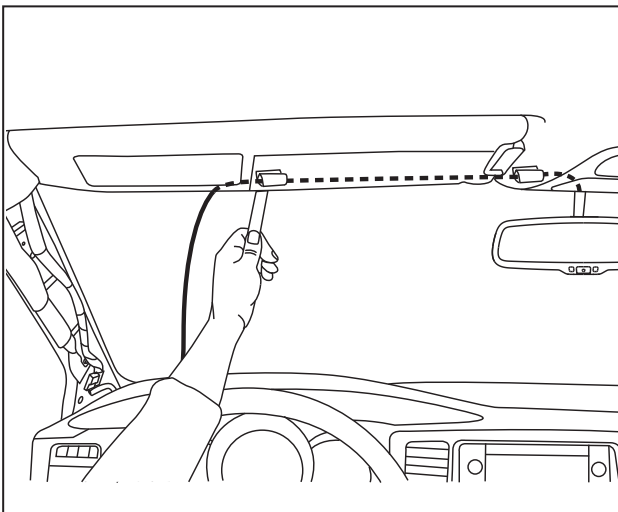

	Panel removal tool	7
NOTE	Tuck EC mirror harness between headliner and roof. Taped portion of EC mirror harness should be centered above visor.	
	CAUTION: Use caution when working with headliner to prevent creases or damage.	

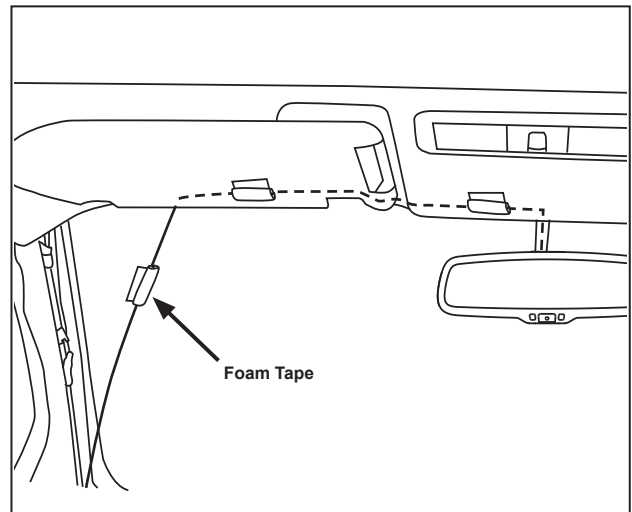

		8
NOTE	Wrap (1) piece of foam tape around EC mirror harness approximately where headliner bends towards driver-side door.	
	CAUTION: Use caution when working with headliner to prevent creases or damage.	

KMA Genuine Approved Accessories (Accessory Installation)

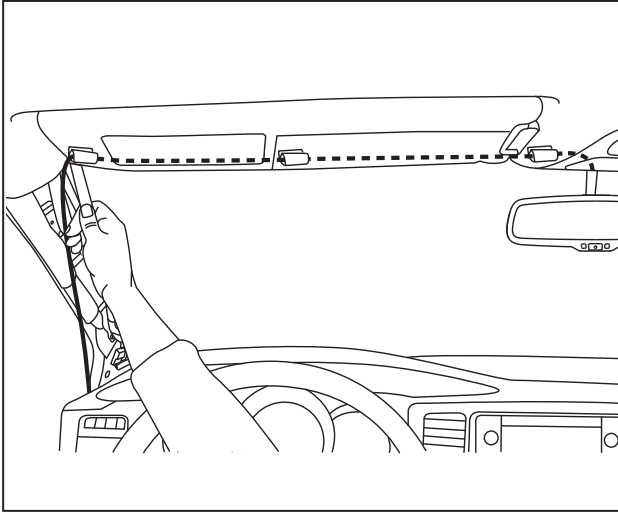

	Panel removal tool	9
NOTE	Tuck EC mirror harness between headliner and roof. Taped portion of EC mirror harness should be where headliner bends towards driver-side door.	
	CAUTION: Use caution when working with headliner to prevent creases or damage.	

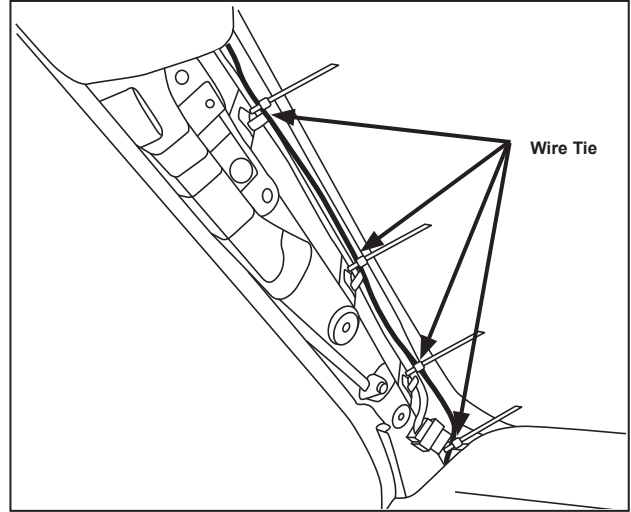

		10
NOTE	Route EC mirror harness down A-pillar and secure to factory wire harness with (4) wire ties.	
NOTE	Clip ends of wire ties.	
	CAUTION: If vehicle is equipped with a sunroof, do not secure wire ties to drain tube.	

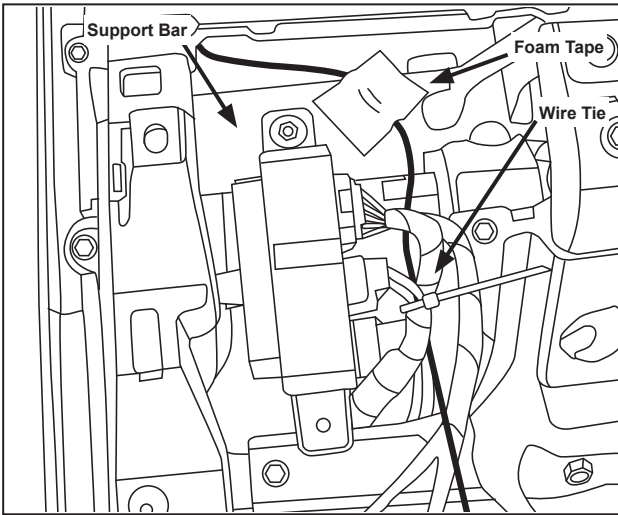

		11
NOTE	Route EC mirror harness through dash, ensuring harness is routed to the front side of the support bar, facing driver. Secure EC mirror harness to support bar with (1) piece of foam tape. Secure EC mirror harness to factory wire harness out of junction block with (1) wire tie.	
NOTE	Clip end of wire tie.	
	CAUTION: Ensure harness is not damaged during routing in front of support bar.	

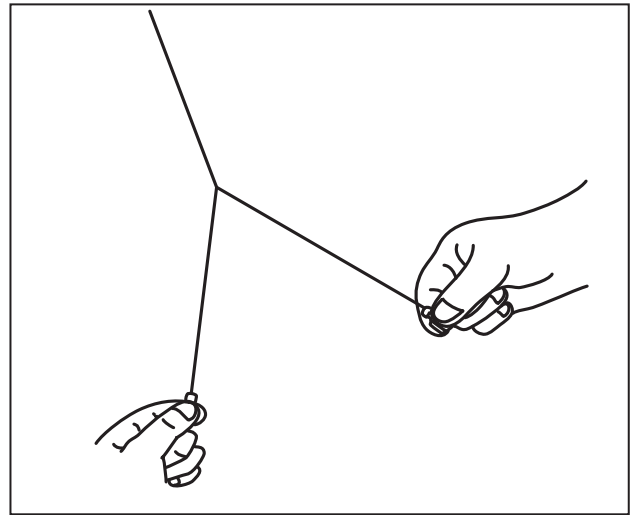

		12
NOTE	Pull EC mirror harness wires apart approximately 10 inches.	

KMA Genuine Approved Accessories (Accessory Installation)

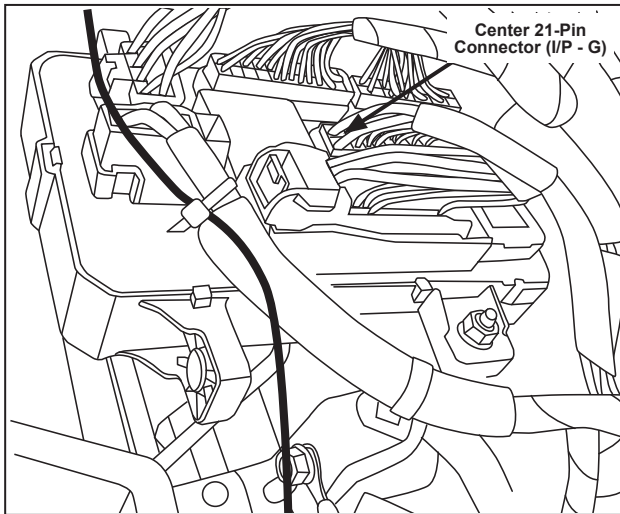

13	
NOTE	Locate the 21 pin connector at the center on the back side of the junction block (Connector I/P - G). Unplug the connector.
	CAUTION: The center connector being removed <u>will not be used</u> for tapping, it is only removed to allow for easier access.

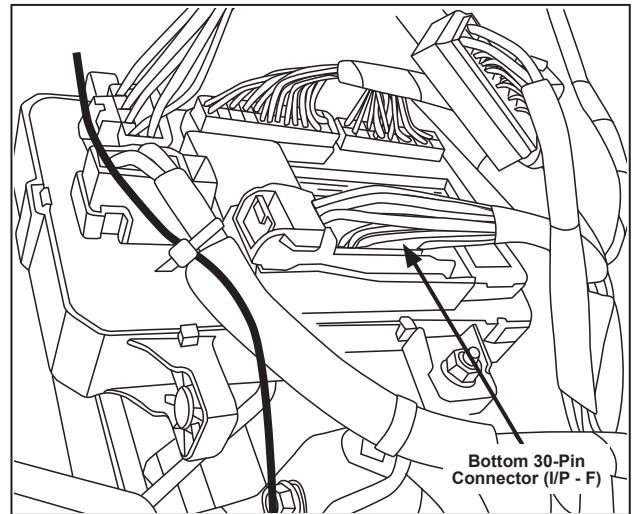

14	
NOTE	Locate the 30-pin connector at the bottom on the back side of the junction block (Connector I/P - F). Unplug the connector.

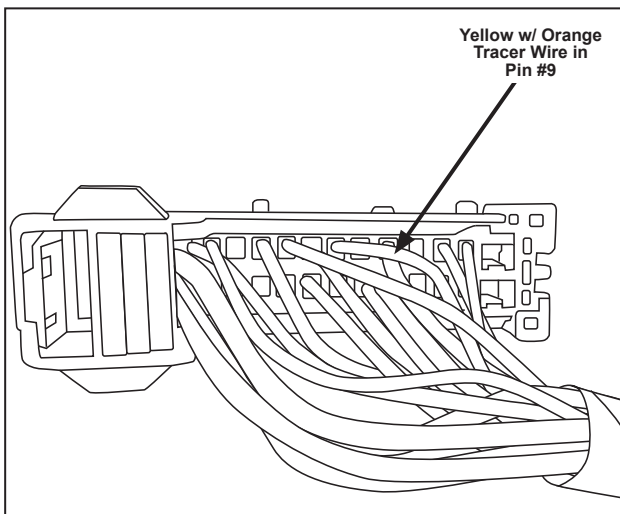

15	
NOTE	Locate the YELLOW w/ ORANGE Tracer wire in Pin #9 of the 30-pin connector (I/P - F).
	CAUTION: Ensure that the correct wire is used.

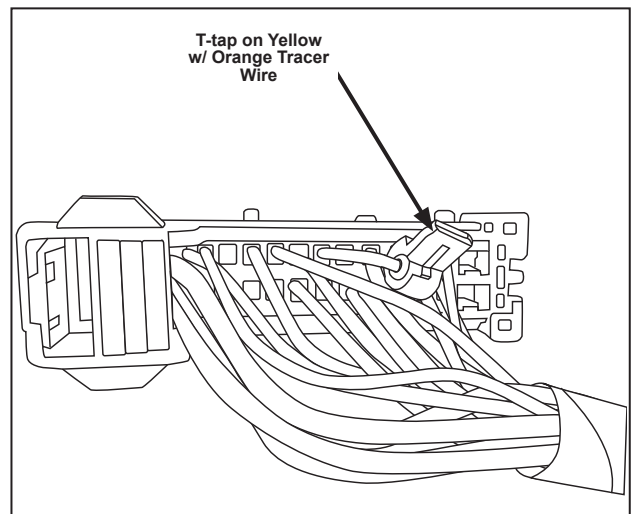

16	Needle-nose pliers
NOTE	Attach t-tap to YELLOW w/ ORANGE Tracer wire in Pin #9. Use needle-nose pliers to snap t-tap together.
	CAUTION: Ensure that the wire is in the slot of t-tap and that both halves of t-tap connector are snapped together properly.

KMA Genuine Approved Accessories (Accessory Installation)

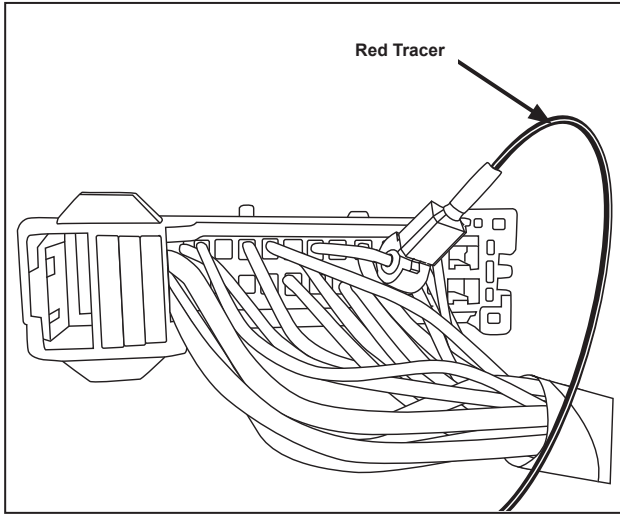

17	
NOTE	Insert spade terminal of the BLACK w/ RED Tracer wire of EC mirror harness into t-tap connector of YELLOW w/ ORANGE Tracer wire (switched IGN 12 Volts).
	CAUTION: Ensure male spade connector is fully inserted into wire tap. Check to see that the spade connector did not miss the slot. Check to see that it is not visible on either side of female connector.

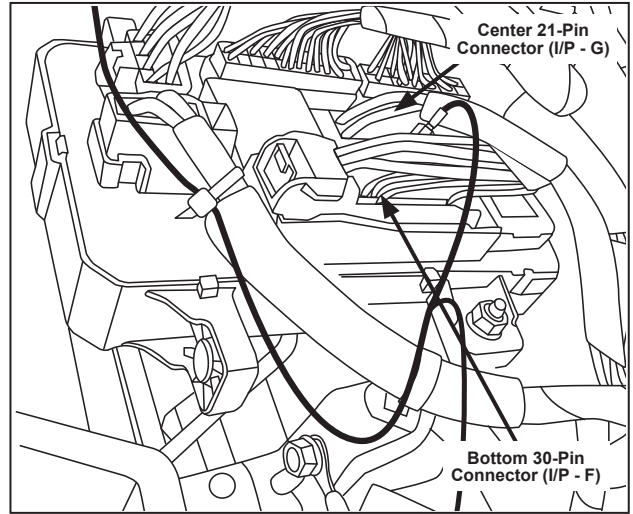

18	
NOTE	Plug 30-pin connector back into the bottom of the junction block, making sure that locking tab on left side of connector is fully seated, then plug 21-pin connector back into the center of the junction block.

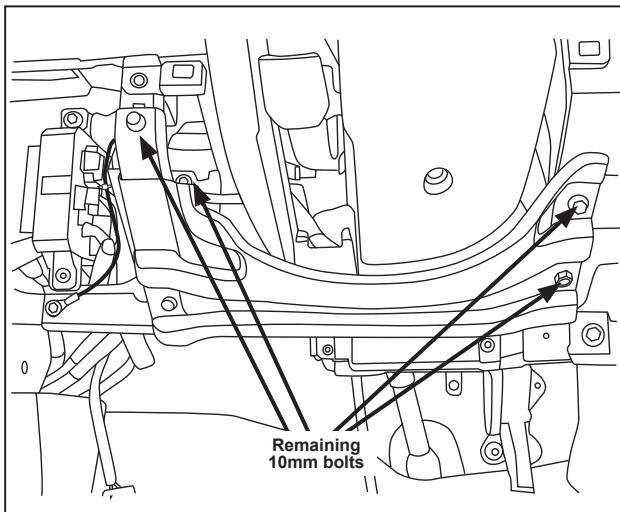

19	Ratchet, 6" Socket Extension, & 10mm Socket
NOTE	Partially reinstall steel knee bolster. Insert the (4) RIGHT MOST bolts through the knee bolster and into the appropriate threaded holes. Securely tighten bolts with 10mm socket.
	CAUTION: Ensure (4) RIGHT MOST bolts are securely tightened. Do NOT install left most bolt until you read step 20.

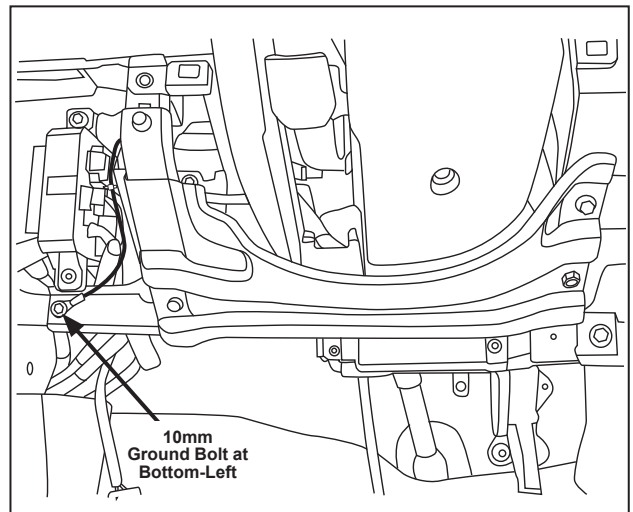

20	Ratchet & 10mm Socket
NOTE	Route ring terminal on Ground wire from EC mirror harness in front of knee bolster. Reinstall the bolt in the BOTTOM - LEFT of the steel knee bolster plate by first inserting the ring terminal over bolt, then going through the knee bolster. Securely tighten bolt with 10mm socket.
	CAUTION: Ensure ground bolt with ring terminal and knee bolster is securely tightened.

KMA Genuine Approved Accessories (Accessory Installation)

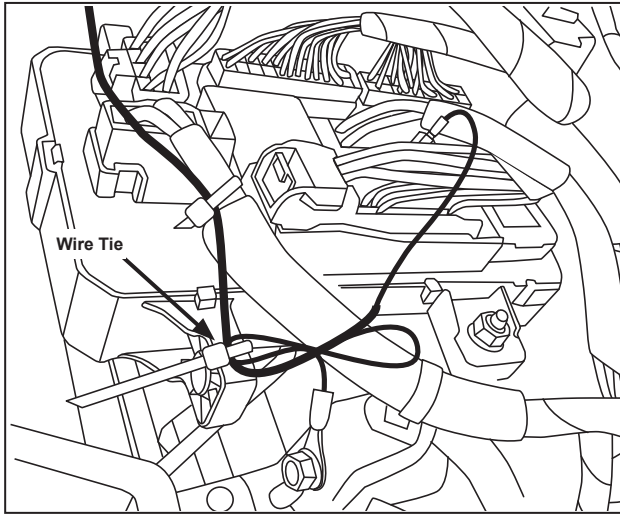

21

**N
O
T
E**

Secure remaining EC mirror harness to bottom of junction block mounting bracket with (1) wire tie.
Clip end of wire tie.

KMA Genuine Approved Accessories (Testing & Re-installation)

	Ratchet & 10mm Socket	1
NOTE	<p>Testing Preparation:</p> <p>Reconnect negative battery cable, using 10mm socket.</p> <p>Reinstall all connectors in lower dash trim panel, including the OBD II connector.</p> <p>Reinstall in reverse order, all trim pieces removed during installation.</p> <p>Turn the ignition switch to the "ON" position.</p> <p>With the vehicle in a fairly well-lit area, perform the following:</p> <p>To make sure the auto-dimming feature is on, verify that the green LED to the left of the center button is on. If it is not on, push and hold the "☀" button for up to 3 seconds to turn the green LED on.</p>	

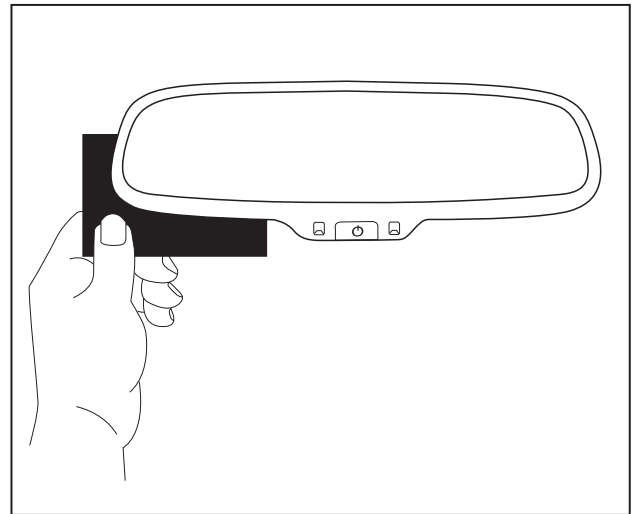

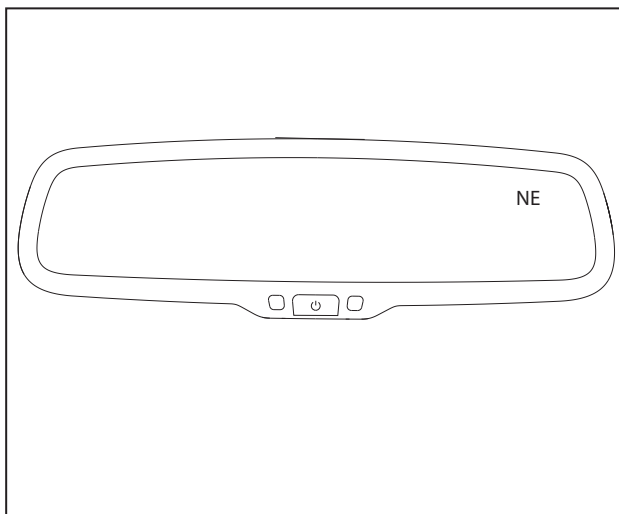

		2
NOTE	<p>Cover the forward looking photocell on the back of the mirror with a dark cloth or towel.</p> <p>In a few seconds the mirror will begin to darken.</p> <p>Remove the cloth from the forward looking photo cell and the mirror will begin to clear.</p>	



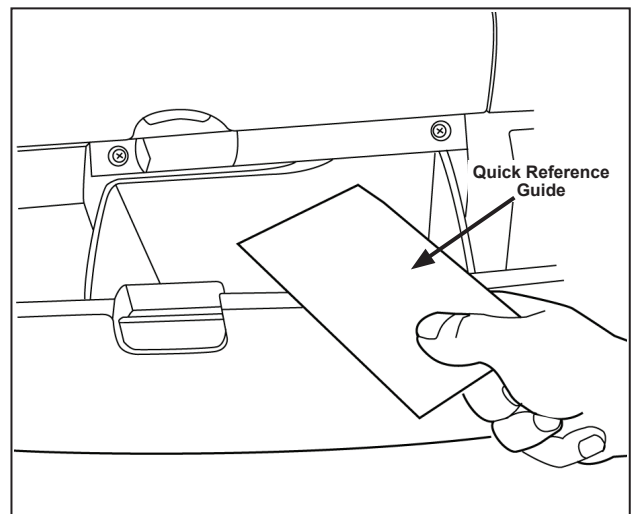







		3
NOTE	<p>Verify that either a direction, such as NE, or "C" is displayed in the display window. If not, ensure the feature is turned on by pressing the "☀" button.</p> <p>Turn the ignition key to the "OFF" position.</p> <p>Testing is now complete.</p>	



		4
NOTE	<p>Place Quick Reference Guide in vehicle glove box.</p> <p>Remove fingerprints, smudges, etc. from mirror.</p>	
	<p>CAUTION: DO NOT spray glass cleaner or other cleaning liquid directly onto the mirror as it may damage the electronics.</p>	

KMA Genuine Approved Accessories Pamphlet (Visual Check)

	Items to Be Checked	Results Of The Check
	Negative battery terminal tightened	Wire is correctly fastened to the negative battery terminal
	Driver-side A-pillar trim	A-pillar trim is securely in place
	Steel knee bolster	All 5 bolts through steel knee bolster are securely tightened, including bottom-left bolt with ring terminal of ground wire properly attached.
	Lower dash trim panel	Lower dash trim panel is securely in place
	Connectors in lower dash trim panel	Connectors removed are securely clipped into lower dash trim panel
	EC mirror torx screw	EC mirror Torx screw is tightened to 15.6 lbs-in (17.9 kg-cm)
	EC mirror harness connector	EC mirror harness connector is securely fastened to power harness.
	EC mirror features: Auto-Dimming	EC mirror dims with key in "ON" position and the forward looking photocell is covered.
	EC mirror features: Compass Display	Compass display reads either "C" or a directional heading with key in "ON" position only and <u>NOT</u> in "OFF" position

KMA Genuine Approved Accessories Pamphlet (Trouble Shooting)

Items In Question	Results Of The Check
Switched harness wire, pin 4 at the mirror harness connector is receiving +12V with ignition ON.	Switched harness wire, pin 4 at the mirror harness connector is receiving +12V with ignition ON.
Ground is present at pin 1 at the mirror harness connector.	Ground is present at pin 1 at the mirror harness connector.
Power harness is fully inserted into mirror harness.	Harness connectors click when fully inserted into each other.
Spade terminal is correctly inserted into T-tap.	Ensure that male spade connector is fully inserted into T-tap. Check to see that the spade connector did not miss the slot and that it is not visible on either side of female connector.
Harness is not pinched, cut, or damaged.	Harness is routed in a manner free of clips and pinch points of trim pieces.

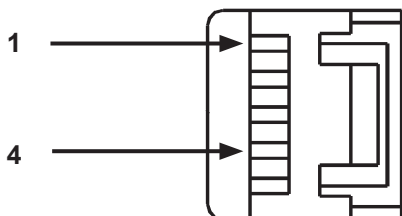

MIRROR CONNECTOR PIN-OUT

NO.	GAGE	COLOR	FUNCTION
1	22	Black	GROUND
2			
3			
4	22	Black w/ Red Tracer	IGNITION (switched 12 volts)
5			